

Instruction Manual

Model GA-72Cd Magnetic Locator

Manufactured By
Schonstedt Instrument Company
100 Edmond Road
Kearneysville, WV 25430
(304) 725-1050
Fax (304) 725-1095

Preface

The Model GA-72Cd® Magnetic Locator is a product of over forty-six years experience in producing the world's finest flux-gate magnetometers and magnetic detectors for aerospace, military and civilian applications. The GA-72Cd® incorporates the knowledge obtained from manufacturing under the most rigid quality control standards. The heart of the GA-72Cd® is its patented Schonstedt HeliFlux® magnetic field sensors. These sensors, acknowledged to be the world's finest, make possible the unequalled performance of the locator.

February 2009

Schonstedt Instrument Company

Table of Contents

Operation	
Introduction	1
Turn-on, Sensitivity and Volume Settings	2
Battery Level Indication	2
Audio Output Selection	3
Search Procedure	4
Application Notes	
Basic Signal Patterns	4
Strongly Magnetized Markers	6
Correct Stake Orientation is Important	7
Locating Manholes, Septic Tanks and Well Casings	7
Locating Objects under Snow or Water and Traced Barbed Wire	8
Searching Areas along a Chain Link Fence	9
Locating Valve Boxes	10
Locating Cast-Iron Pipes	10
Locating Steel Drums	11
Locating Nonmetallic Duct and Cable	11
Locating Ordnance and Weapons	12
Additional Applications	13
Other Notes	13
Data Logger Output	14
Maintenance	
Replacement of Batteries	14
Troubleshooting Guide	15
GA-72Cd Repair Parts	16
Service Information	17
Specifications	17
Warranty/Shipping Information	18

Important Notice

Schonstedt believes the statements contained herein to be accurate and reliable. But their accuracy, reliability, or completeness is not guaranteed.

Schonstedt's only obligation shall be to repair or replace any instrument proved to be defective within five years of purchase. Schonstedt shall not be responsible for any injury to persons or property, direct or consequential, arising from the use of any instrument.

OPERATION

Introduction

The Model GA-72Cd Magnetic Locator detects the magnetic field of ferromagnetic objects. It responds to the difference in the magnetic field between two sensors which are spaced about 14 inches apart. The GA-72Cd is unique because it provides an audio signal, and visual indications of both signal strength and polarity. Although most objects can be located using either of the indications, simultaneous use of both types will help you pinpoint a target and determine its orientation and identify magnetically detectable nonmetallic duct and cable.

Figure 1 illustrates an application of the locator in which it is used to detect an iron marker of the type used for property line identification. As shown, the magnetic field of the iron marker is stronger at sensor **A** than it is at sensor **B**. As a result, the frequency of the audio signal is higher than the idling frequency, 40 Hz, which exists when the field strength is the same at both sensors. This stronger signal also causes the digital indication to peak in either the positive or the negative direction when the audio signal is at its highest frequency.

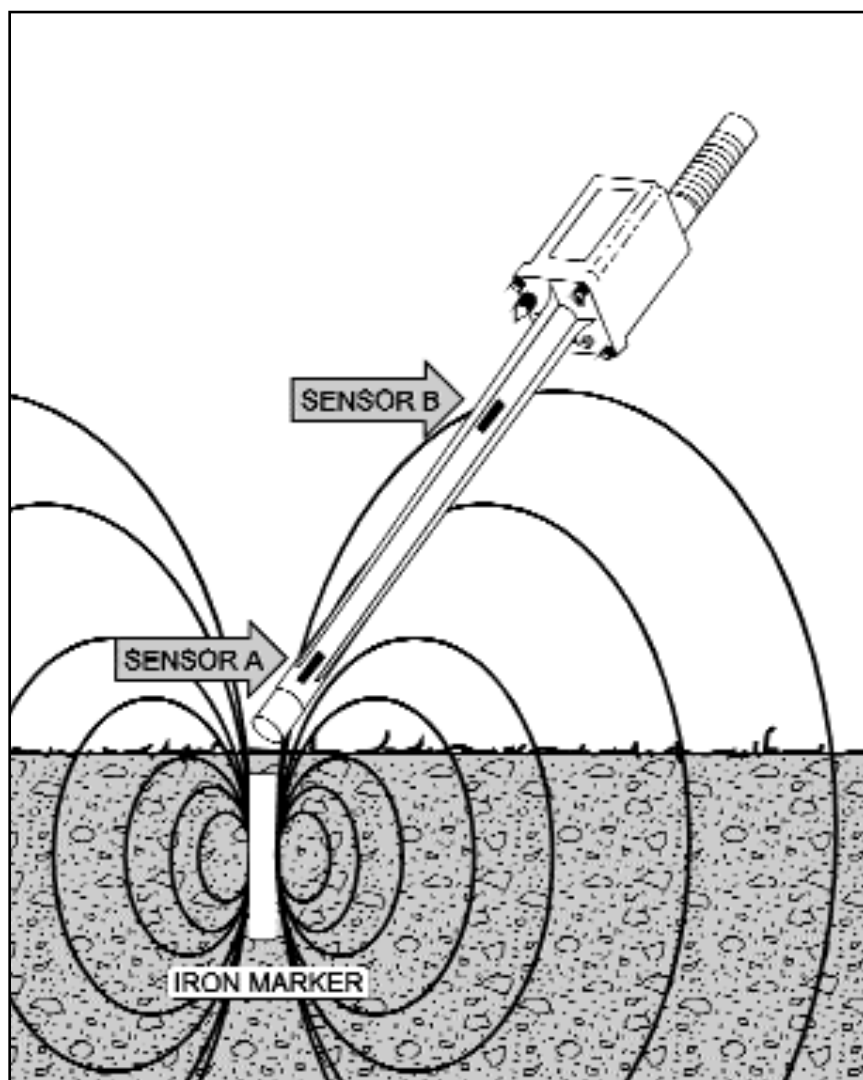

Figure 1. Detecting Magnetic Field of an Iron Marker

When shipped, the locator is set to provide an audio signal which is heard as long as the instrument is turned on. If desired, you can change this to an audio signal which is heard only when the instrument is within detection range of an object by using the internal Audio Output Switch as described on page 4 of this manual.

Turn-On, Sensitivity and Volume Settings

Turn on the GA-72Cd by rotating the On/Off-Sensitivity control knob clockwise to position 1. This sets the sensitivity to what is referred to as the Normal Range (the L meter indication). You can increase the sensitivity by rotating the Sensitivity control clockwise to select M, H, or XH settings as indicated on the meter’s GAIN display. Adjust the Volume control for the desired audio output level.

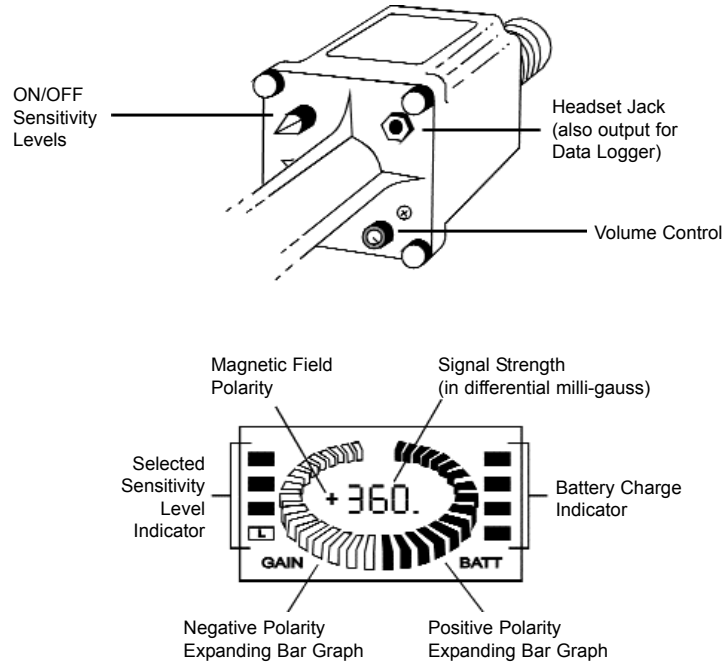

Figure 2. Control and Meter Indications

Battery Level Indication

The meter’s BATT indication displays the batteries’ voltage level. As shown in Figure 3, when all four segments are black the voltage level is between 100% and 25% (up to 60 hours of operation with intermittent usage). As the voltage decreases, the number of black segments decreases. Battery life varies with usage and the ambient temperature. Cold temperatures reduce battery life. Low temperatures may result in only two or three segments being black. This could be temporary and all segments will change back to black as the temperature increases.

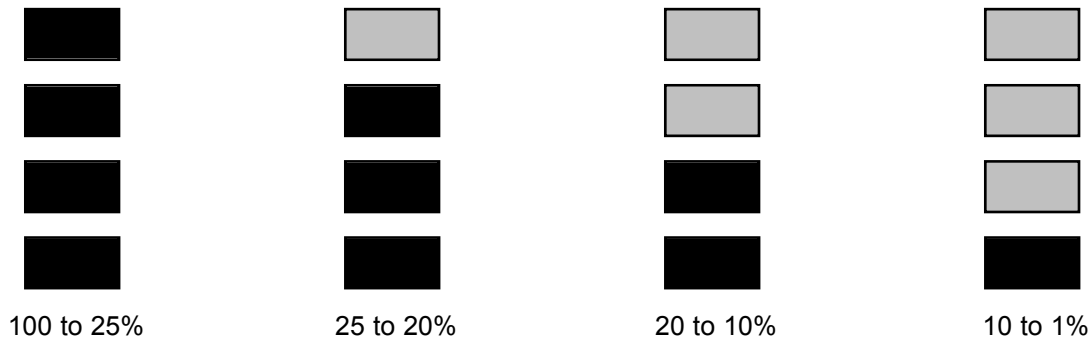

Figure 3. Battery Voltage Status Indications

Audio Output Selection

All GA-72Cd's are shipped from the factory with the Audio Output Switch set to "B". This provides an audio signal that is always present. If you prefer not to hear a signal until the locator is within detection range of a target, set the switch to "A".

Audio Signal with Output Switch set to "A"

No audio signal is heard until the GA-72Cd comes within detection range of a ferromagnetic object. As you move the locator across the object, frequency of the signal does not change but unit **increases in volume** over the object, then decreases in volume and turns off when the locator is moved out of range.

NOTE: If you put the GA-72Cd down without turning the Sensitivity/Power switch to Off, the "power-on monitoring feature" (designed to conserve battery life) will initiate a beeping audio-alert signal after 15 seconds.

Audio Signal with Audio Output Switch set to "B"

As you move the GA-72Cd across a ferromagnetic object, the 40 Hz idling signal, which is always present, increases in frequency, peaks when the locator is directly over the object and then decreases to 40 Hz.

Regardless of which switch setting, the indication of signal strength and the polarity on the meter will always peak (positive or negative) when the locator is directly over a ferromagnetic object.

As shown, the cover must be removed to change the setting of the Audio Output Switch.

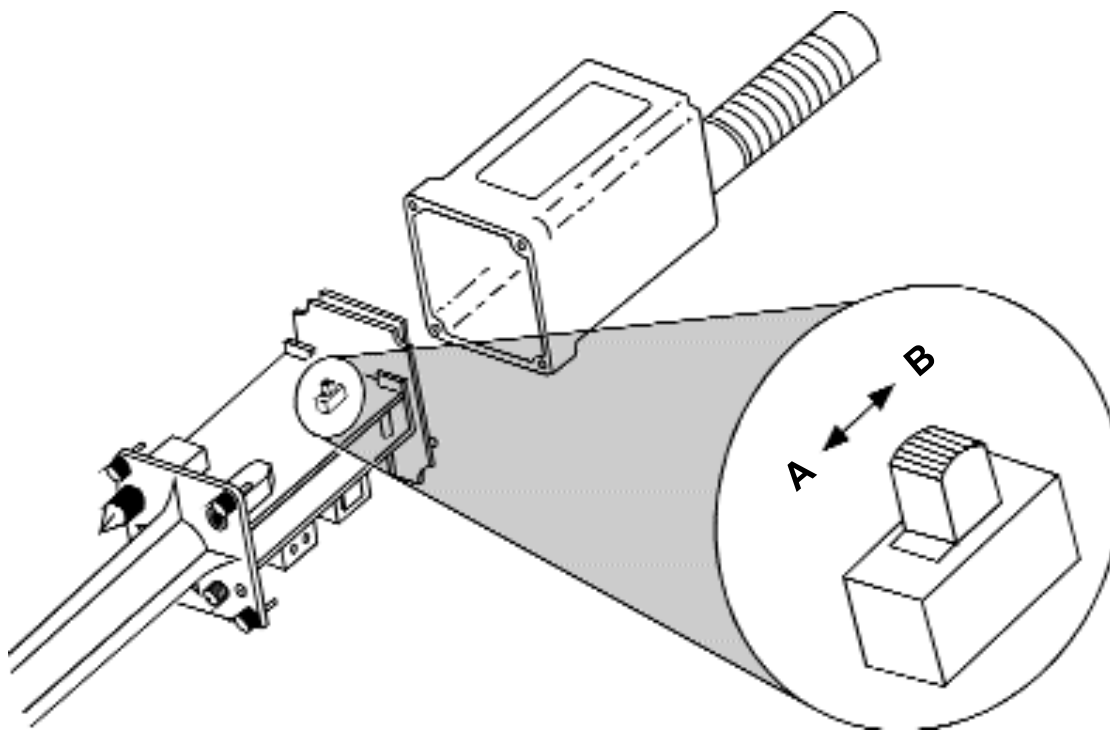

Figure 4. Location of Audio Output Switch

Search Procedure

Set the On/Off-Sensitivity control for L and grasp the locator as illustrated. Because the upper sensor is near the locator's handle, wrist-watches may produce unwanted changes in the audio signal and in the meter indications, and should be removed. Keep the locator away from your shoes since they might contain magnetic material. To obtain maximum area coverage, sweep the locator from side to side. When the locator comes within range of an iron object, the audio signal will peak, the bar graph will expand positive or negative, and the digital readout will peak as shown in Figure 6.



Figure 5. Searching With the Locator

When the GA-72Cd is positioned directly over a vertical pipe, the audio and digital indications will peak. The expanding bar graph and digital readout may be either a positive or negative level.

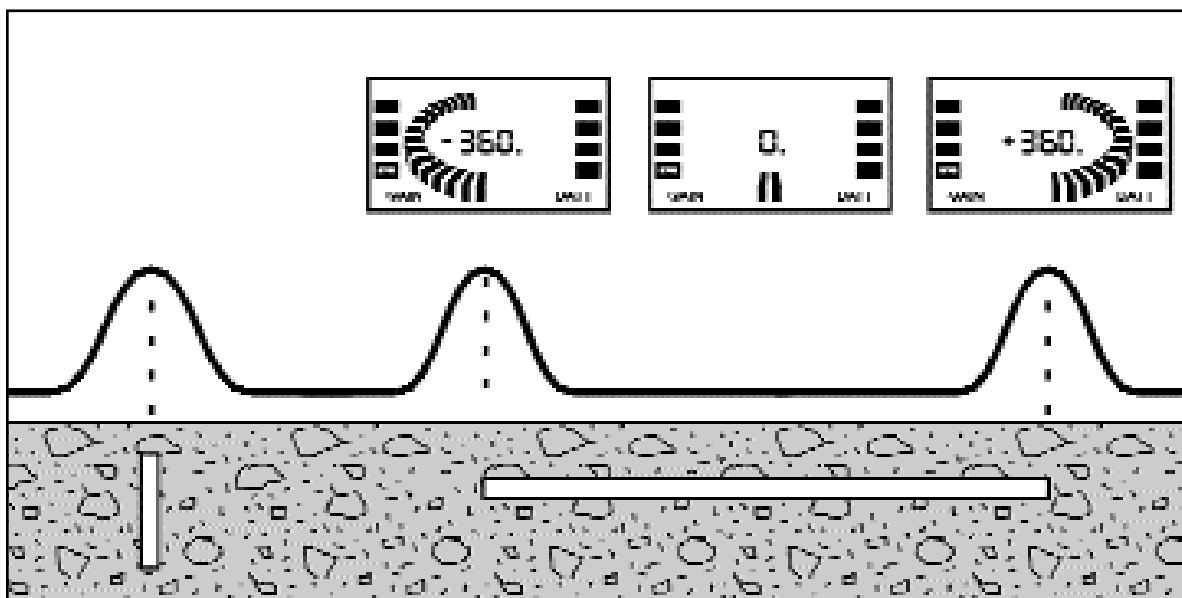

Figure 6. The Meter's Polarity Indications Help to Determine Target Orientation

The audio signal, bar graph and digital indications peak over each end of a horizontal pipe. One end is positive, the other is negative. This will help you to distinguish between two vertical pipes or one horizontal pipe. Usually two vertical pipes buried in close proximity will produce digital indications with the same polarity.

APPLICATION NOTES

Basic Signal Patterns

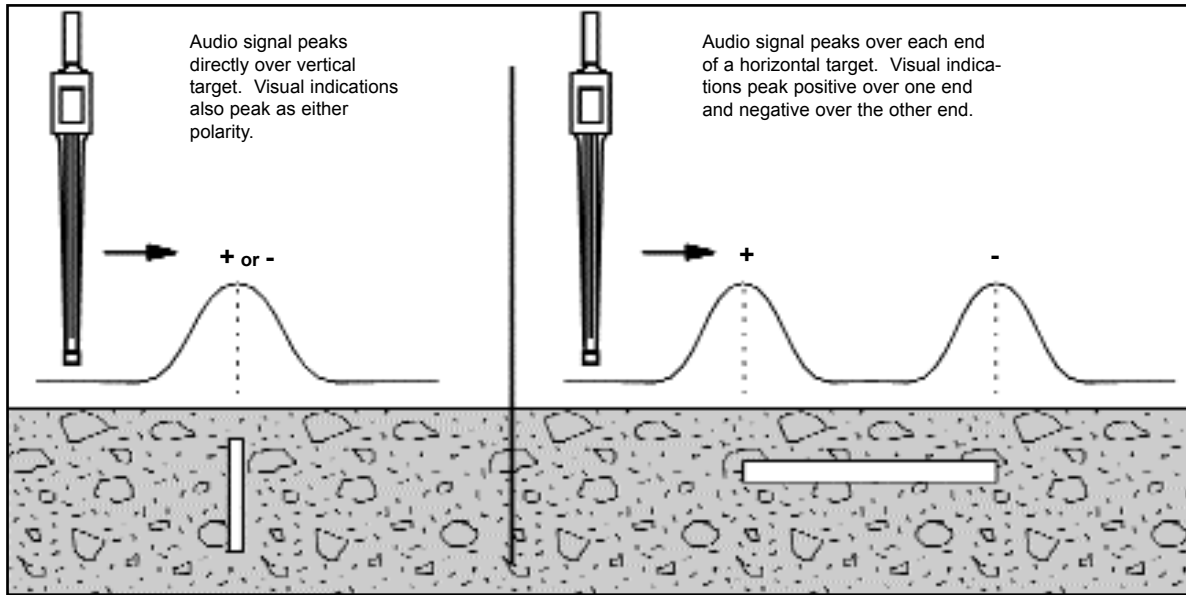

Figure 7. Signals from Vertical and Horizontal Targets

After you have detected the presence of a target, hold the locator vertically and slowly move it back and forth in an “X” pattern while observing the digital readout. The value of the number will be highest when the locator is directly over a target, and over the ends of a horizontal target. The “X” pattern is ideal for pinpointing small objects. A 1-1/4 inch PK nail buried up to 8 inches can be located so precisely with this technique that it can be uncovered using a 1/2 inch star drill.

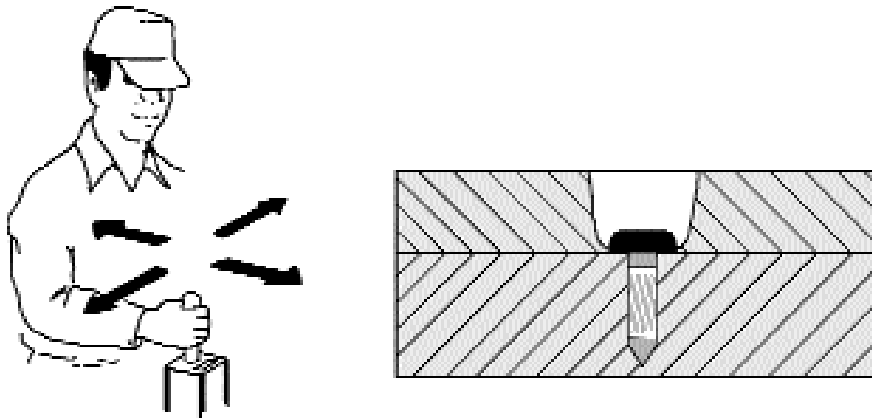

Figure 8. “X” Pattern provides Precision Locating

If you are looking for a corner marker and detect two or three signals in the same general vicinity, raise the locator several inches above the ground or reduce the sensitivity setting before you get a shovel. Any signal that disappears when the locator is held higher is probably coming from a shallow target. The signal from a rusty bolt or other small item (see Figure 9.) decreases much faster with distance than the signal from a larger target such as a 18-inch length of 3/4 rebar which can be located at depths up to 7 feet.

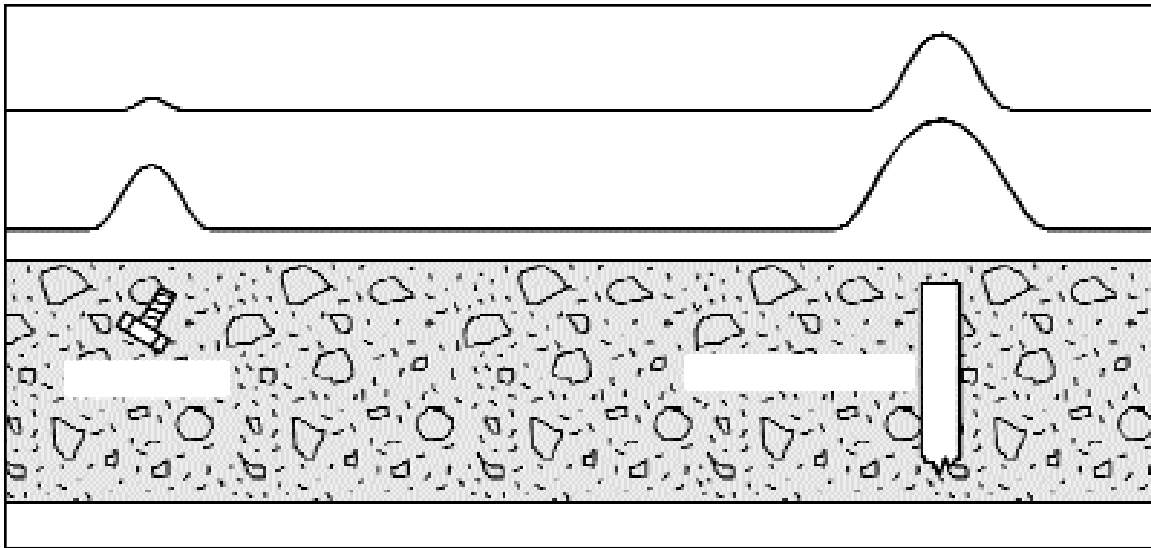

Figure 9. Raising the Locator Eliminates Unwanted Signals

Strongly Magnetized Markers

A strongly magnetized marker at or near the surface provides a weaker indication on both sides of the marker that could be mistaken for the marker.

The heavy line in Figure 10 represents the increase and decrease in the audio and digital indications as you move the locator over a marker. Between points **A** and **B** the signals increase slightly and then decrease. Just beyond **B** the signals increase rapidly, peak directly over the marker and then decrease at point **C**. From **C** to **D** the signals increase and decrease again. So if you do not move the locator completely across the marker you might assume that the weaker indication on either side of the marker is its location.

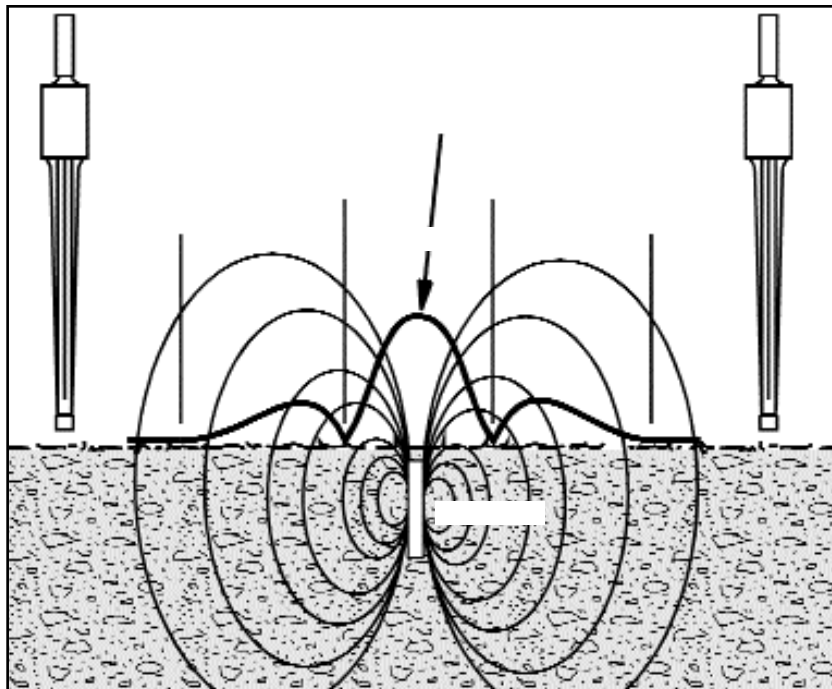
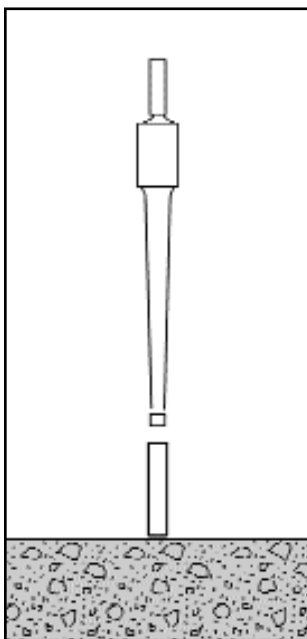

Figure 10. Signal Pattern from a Strongly Magnetized Marker

The two weaker indications occur because the locator is extremely sensitive to the magnetic field components parallel to its long axis. At point **B** and **C** the field is perpendicular to the locator so no peak audio or digital indications are produced at these points.

When Placing Stakes Correct Orientation is Important



For checking purposes, the orientation of the pin relative to the locator is shown in Figure 11. Check the pin with one orientation. Then rotate the pin 180°. The orientation which gives the largest reading is the one that should be used. This reading would be positive in the Northern Hemisphere, and negative in the Southern Hemisphere (Australia, New Zealand, etc.)

An iron pin has two types of magnetization. One is the magnetization induced by the Earth's magnetic field. The induced magnetization is always downward in the Northern Magnetic Hemisphere and produces a positive output no matter which end of the stake is driven into the ground. The other type of field is the permanent magnetization which is fixed to the pin. For maximum detection, the stake should be driven into the ground such that the permanent magnetization is in the same direction as the induced magnetization.

Locating Manholes, Septic Tanks and Well Casings

The magnetic field is strongest at the edge of a shallow manhole cover. You can easily trace the edges of covers near the surface. Locating depth ranges up to 8 feet.

The great length of a well casing provides a strong field at the surface that makes it easy to locate casings buried up to 15 feet deep.

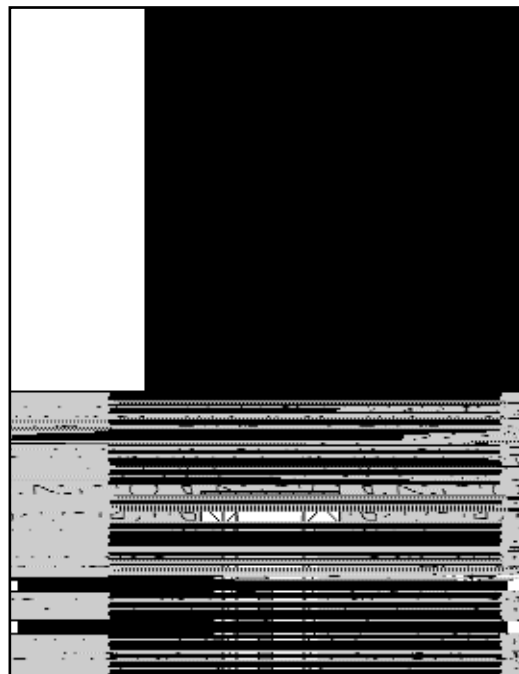
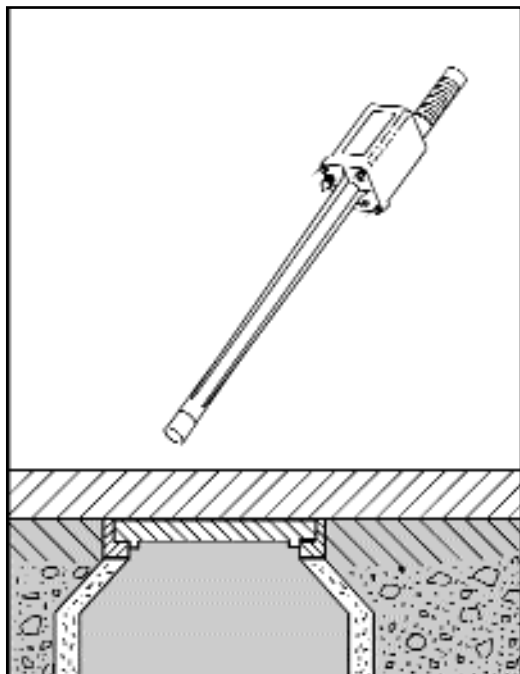

The GA-72Cd can be used to precisely locate the metal handles or reinforcing bars on septic tank covers at depths up to 4 feet.

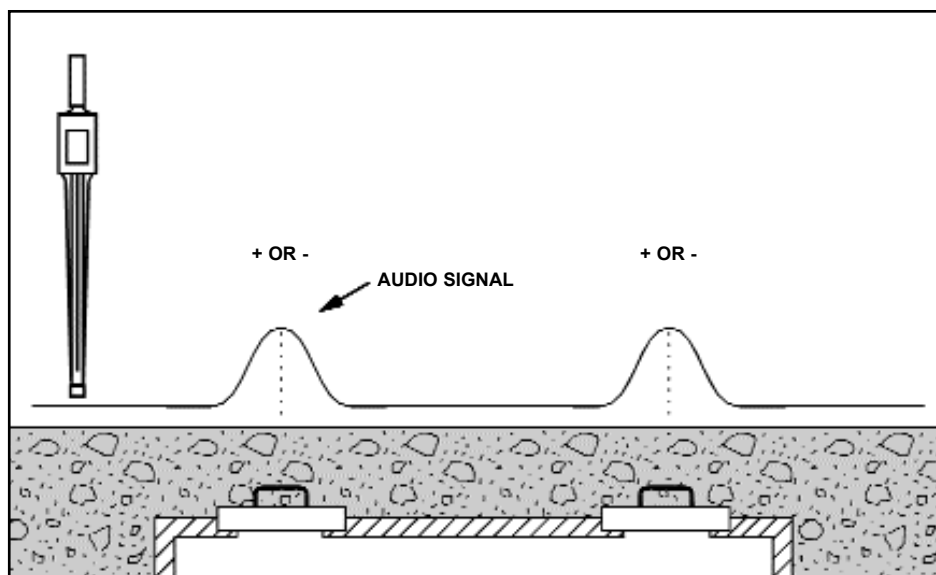

Figure 14. Signal Patterns Provided by Septic Tank Covers

Locating Objects Under Snow or Water and Tracing Barbed Wire

The locator can be used in snow or in flooded areas - just keep the electronic unit out of the snow or water.

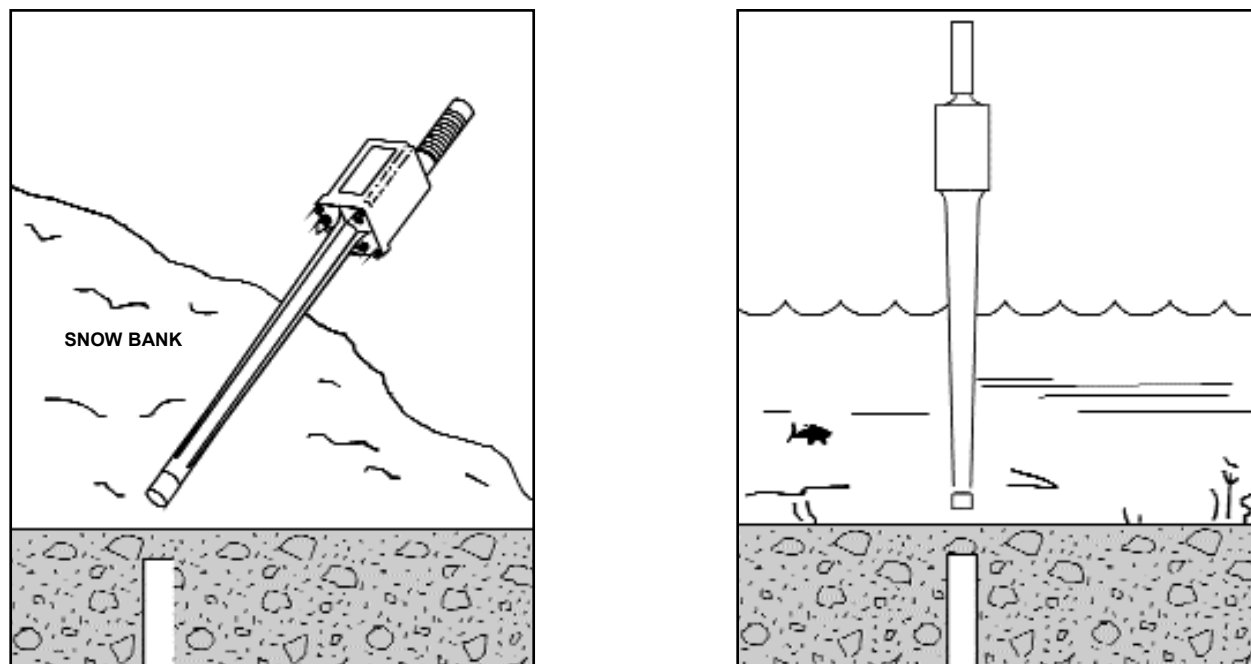

Figure 15. Locating Objects under Snow or Water

You can often trace barbed wire (from old fence lines) buried just beneath the surface. Even if the wire is only a trail of rust, it can still be detected near the surface. Tip the locator a little lower than usual - but not parallel with the ground.

Examine trees for bench marks and bits of embedded barbed wire. Hold the locator parallel with the direction of the wire.

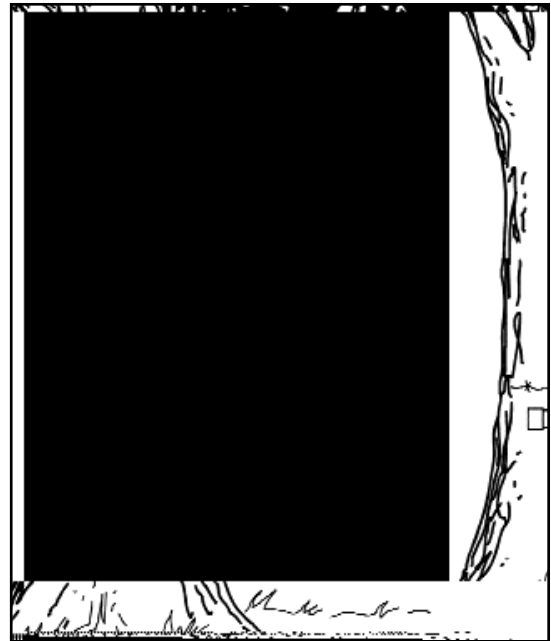
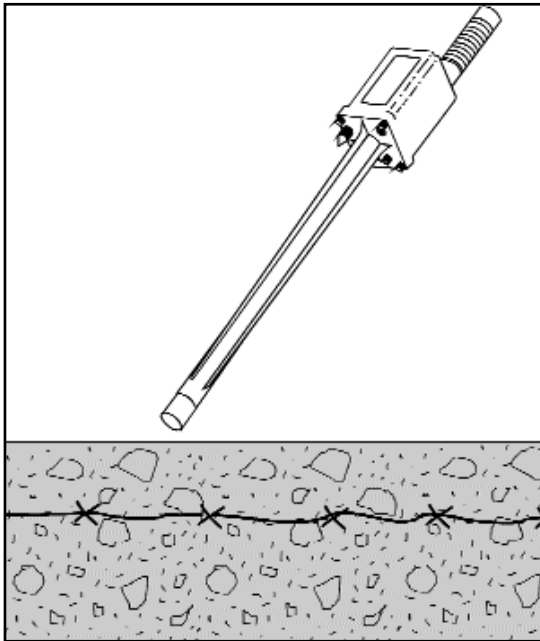

Figure 16. Tracing Barbed Wire from Old Fence Lines

Searching Areas Along a Chain Link Fence



Searching in the vicinity of a chain link fence requires a reduced sensitivity setting and some control over the orientation of the locator. Position the locator horizontally with its long axis perpendicular to the fence as illustrated in Figure 17. This insures that the upper sensor is kept away from the fence.

Perform the search by slowly moving the locator forward along the fence while also moving it to the right and to the left. This technique allows you to search an area several feet wide as you move forward. Listen for an abrupt drop in the signal (as shown by the null in Figure 18) that will occur when the lower sensor, located 1-5/8 inches from the end of the locator, is directly over the stake. Any variation in the position of the locator will produce an abrupt rise in the frequency of the signal.

Figure 17. Searching in the Vicinity of a Chain Link Fence

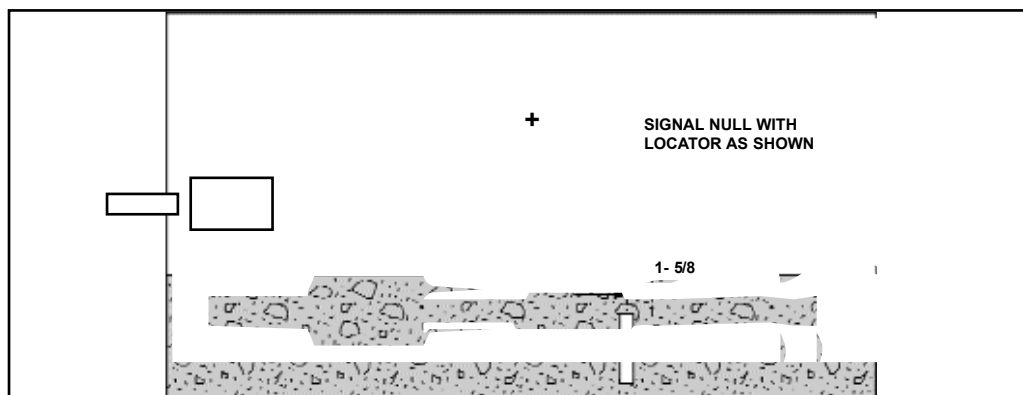

Figure 18. Placement of Locator while Searching along a Chain Link Fence

Locating Valve Boxes

Both the valve and its casing, when iron, provide strong magnetic fields which make them easy to locate. Plastic enclosures containing magnets are easily located at depths of 6 feet or more.

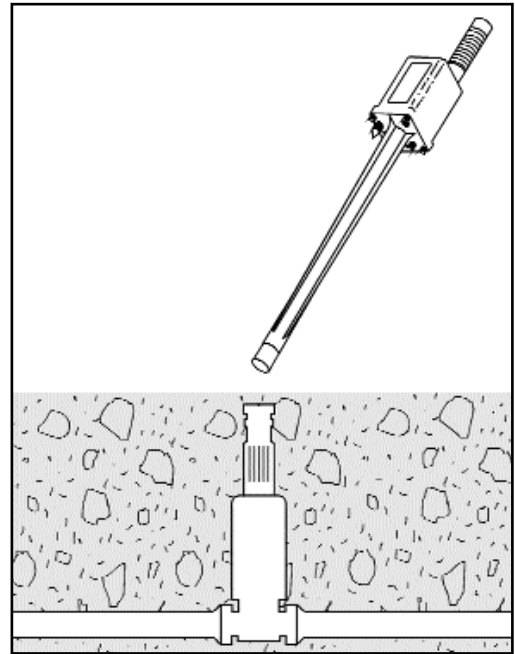

Figure 19. Locating Valve Boxes and Casings

Locating Cast-Iron Pipes

As illustrated in Figure 20, cast-iron pipes produce the strongest magnetic signals at their joints.

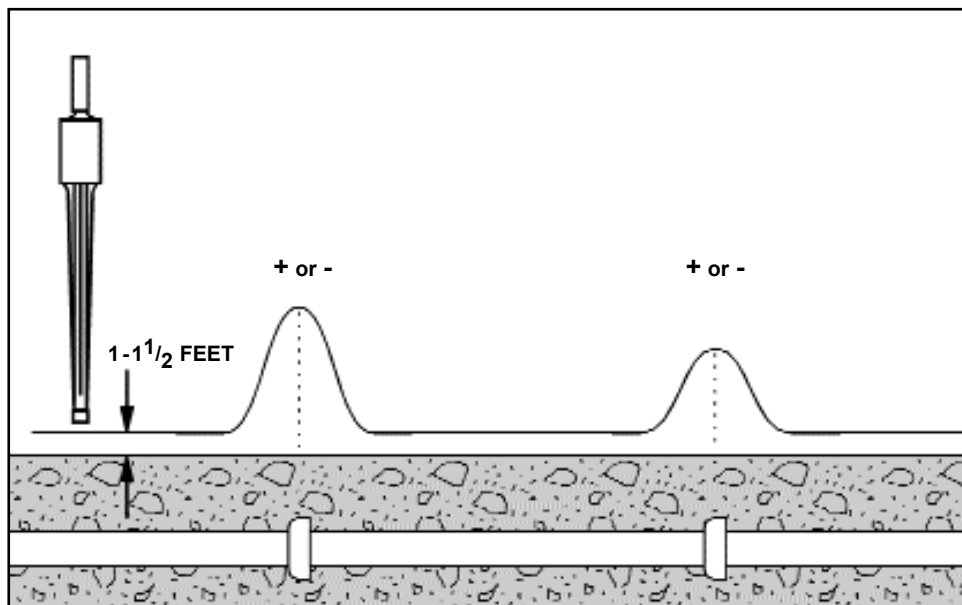

Figure 20. Signal Patterns Provided by Cast-Iron Pipes

The initial search should be performed as follows:

1. Set the Sensitivity control for maximum (XH indication).
2. Hold the locator vertically approximately 1 to 1-1/2 feet above the surface.
3. Walk along without turning or tilting the locator.
4. Mark the locations where the maximum signal levels occur.
5. Return to an area of maximum signal strength and hold the locator several inches above the surface. The sensitivity will probably have to be reduced during this second pass. Four-inch pipes can be located at depths up to 8 feet.

Locating Steel Drums

As shown in Figure 21, the GA-72Cd's signal pattern will vary depending on the vertical or horizontal orientation of the drum and also how deep it is buried. A fifty-five gallon drum can be located at depths up to 8 feet.

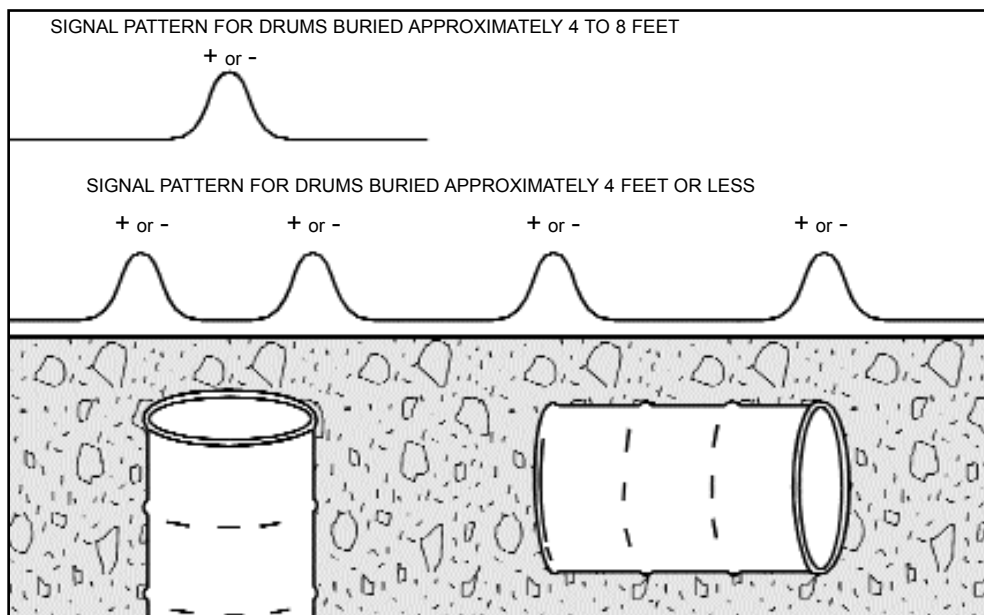

Figure 21. Signal patterns provided by steel drums

Locating Magnetized Nonmetallic Duct and Cable

Schonstedt's patented technology for incorporating magnetic materials into nonmetallic duct and cable makes it easy to locate these objects at various depths as listed in Table A.

This technology also provides "magnetic signatures" consisting of positive and negative polarities that alternate at specific intervals. Different intervals (see Table A) provide each of the three categories of duct and cable with a unique magnetic signature used for positive identification. Magnetic signatures also help to distinguish nonmetallic duct and cable from cast-iron or steel pipe.

Table A. Magnetic Signatures and Detection Depths for Magnetized Metallic Duct and Cable Applications

APPLICATION	MAGNETIC SIGNATURE (Meter alternates between positive and negative)	DETECTION DEPTH*
CATV (duct/cable)	Every 4 feet	Up to 4 feet
Telephone	Every 6 feet	Up to 5 feet
Electrical (duct)	Every 7 feet	Up to 5 feet

* Sensitivity set to XH

As shown in Figure 22, a magnetized nonmetallic fiber optic cable is easily identified by the GA-72Cd's visual indication which changes from positive to negative every six feet along with the audio signal which also peaks every six feet.

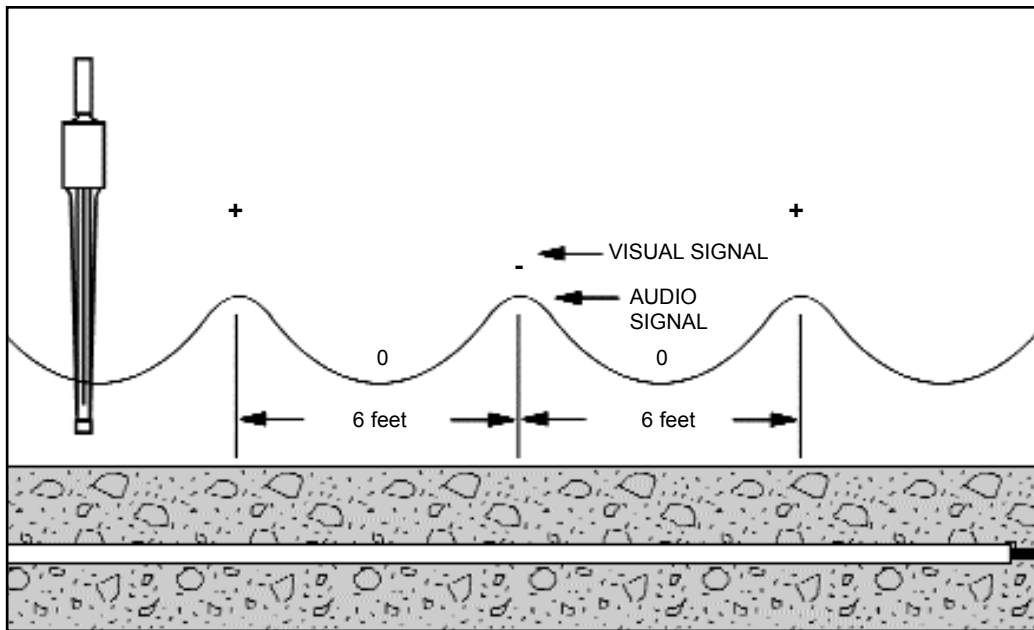
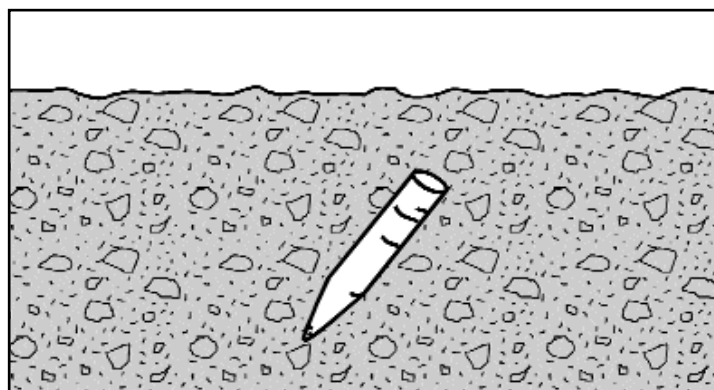
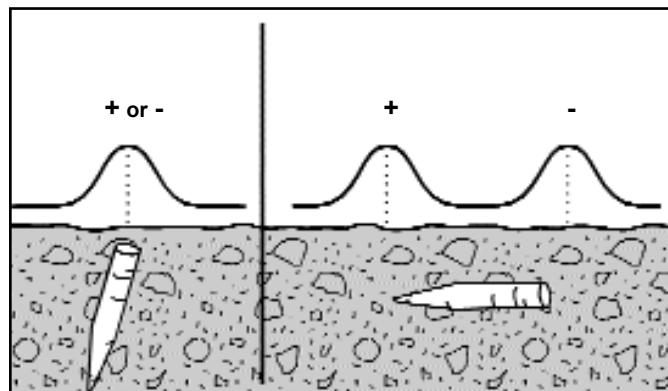

Figure 22. *Magnetically Detectable Nonmetallic Cable Provides a Unique Magnetic Signature*

Locating Ordnance and Weapons

The versatile, lightweight, cost-effective GA-72Cd is also designed to aid EOD technicians and law enforcement officers during area search operations.

Basic signal patterns from vertical and horizontal targets help to determine target orientation.



A 175mm projectile can be located up to 5 feet deep.

An 81mm mortar can be located up to 12 inches deep.

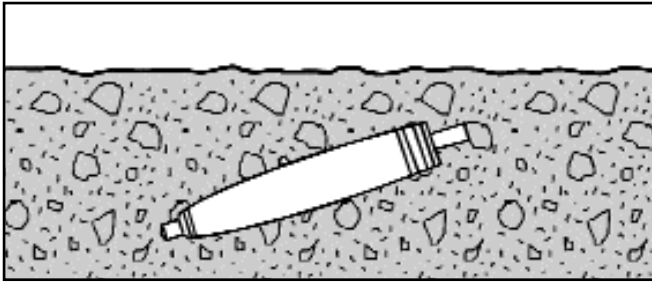
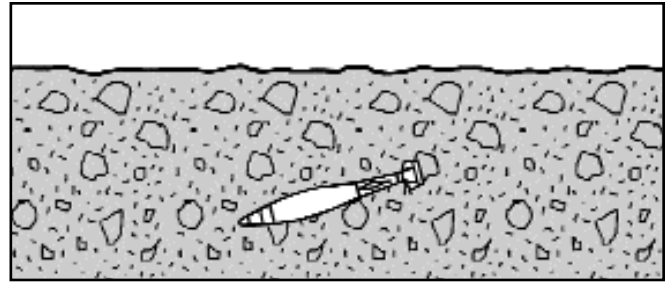

MK81 Low drag bombs can be located up to 9 feet deep.

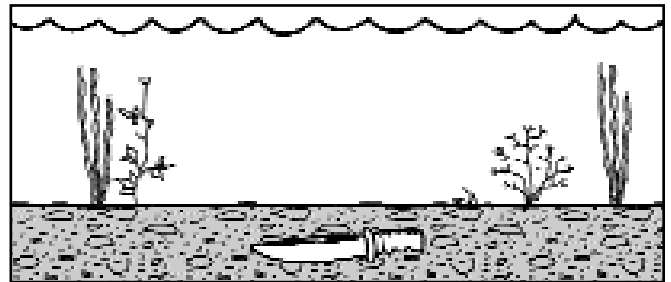

A hunting knife under water can be located in up to 16 inches of silt.

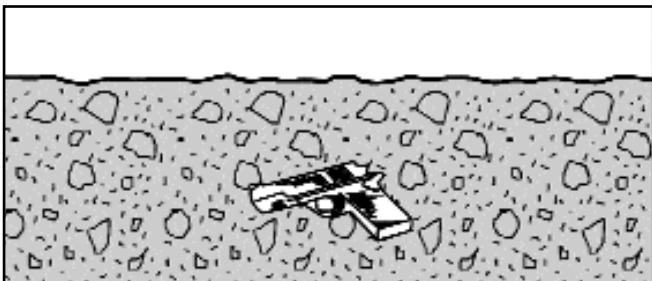

A discarded hand gun can be located up to 12 inches deep

Additional Applications

1. People drilling in an area where hazardous materials might be encountered should use the GA-72Cd to search the area prior to drilling. Other Schonstedt gradiometers are available that can be lowered down the drill hole for periodic checks as drilling progresses.

Other Notes

1. A burbling sound indicates the presence of an energized power line. This will not influence the meter indication unless associated with a magnetic structure.
2. The instrument will not respond to nonmetallic materials such as gold, silver, copper, brass and aluminum.

DATA LOGGER OUTPUT

The headset jack also provides an analog output signal for input to a data logger. This ± 4 volt signal varies in proportion to signal strength and is accessible by wiring a standard stereo plug as illustrated in Figure 23.

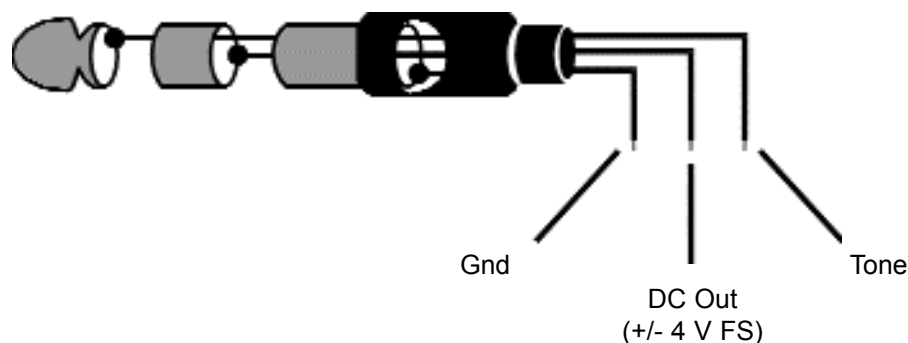

Figure 23. Stereo Plug Connections for Analog Output Signal

MAINTENANCE

The GA-72Cd is designed and built to give trouble-free operation. Normally, maintenance is limited to the occasional replacement of the batteries. In the event a malfunction does occur, refer to the Troubleshooting Guide on page 15 for a few problems that you can correct in the field.

Replacement of Batteries

The GA-72Cd is powered by two 9-volt lithium batteries which have a shelf life of ten years, and provide twice the operating life of alkaline batteries. Access to the batteries is obtained by loosening the four captive screws and removing the electronics cover as shown in Figure 24.

CAUTION

Always use lithium batteries. Alkaline batteries produce magnetic fields that will affect performance of the locator particularly when set to the H or XH sensitivity range.

The locator is shipped with a spare set of lithium batteries conveniently stored in the carrying case. It is recommended that when you use the spare batteries, replace them as soon as possible so that you will never be without batteries in the field.

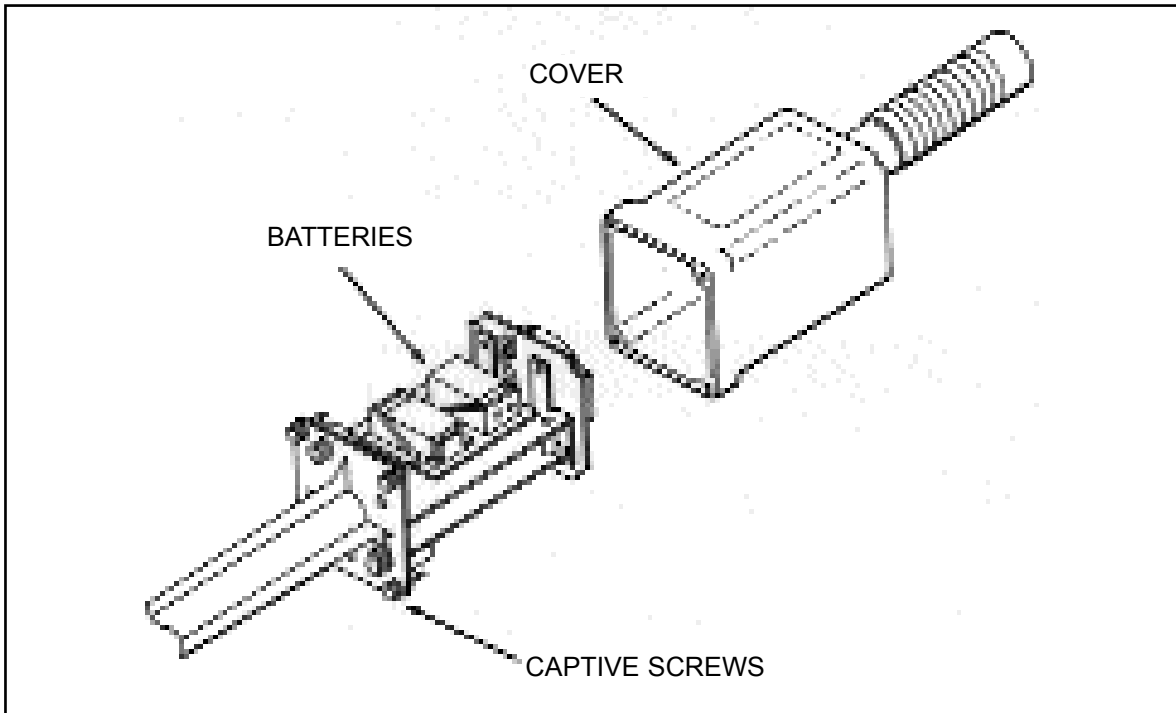
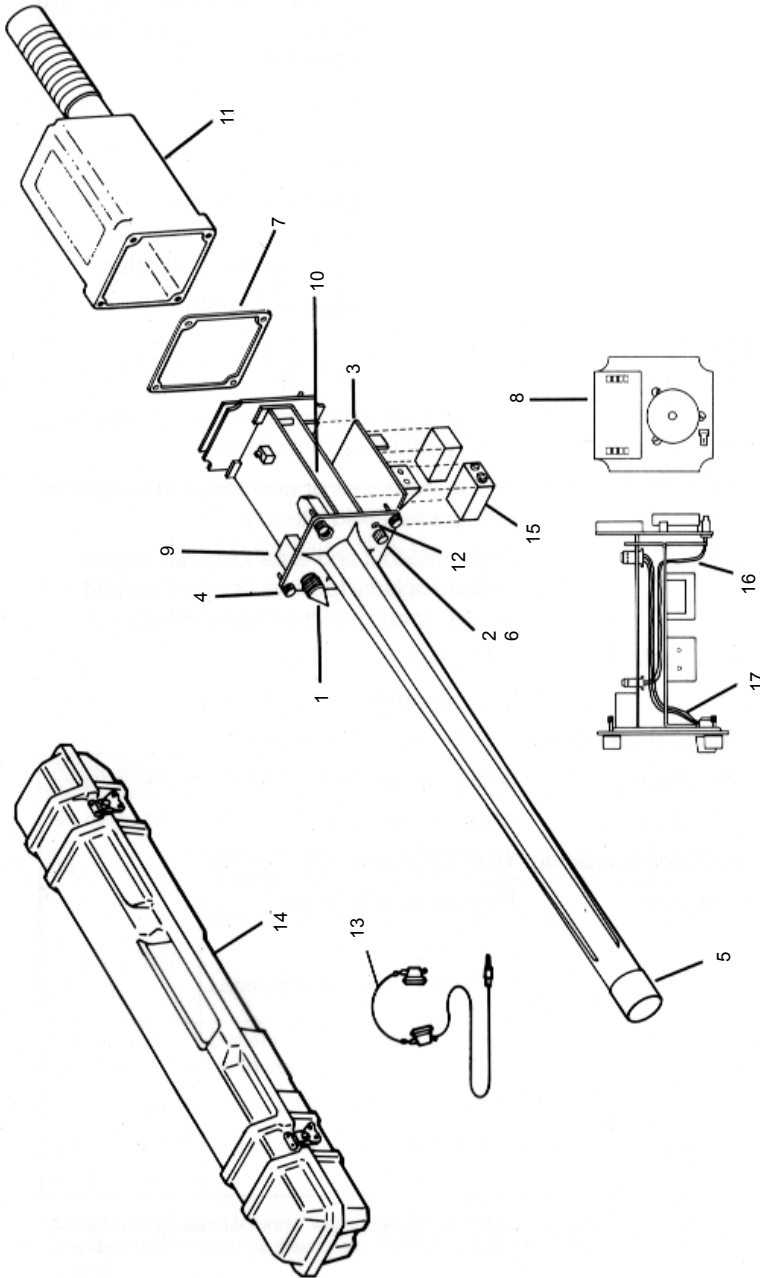

Figure 24. Exploded View of the Electronic Unit Cover

Troubleshooting Guide

Symptom	Possible Cause	How to Check	How to Fix
No response	Dead batteries	Replace	—
	Batteries not making contact	Check for contact corrosion	Clean contacts
	Battery leakage	Do not remove batteries*	Return unit to factory
	Loose connector(s)	Visually inspect	Reconnect
Intermittent	Batteries not making good contact	Check for corrosion	Clean contacts
	Loose connector(s)	Visually inspect	Reconnect
Uncontrollable screaming	Weak batteries	Replace	—

*Most battery manufacturers' warranties cover the cost of repair or replacement of any device damaged by their batteries. Removing batteries that leak will void their warranty.



ITEM	PART NO.	DESCRIPTION
1	K20015	Knob, Pointer
2	K20013	Knob, Round
3	208306	Battery Bd. Assy.
4	208282	Captive Screw (4 Req'd)
5	208195	Tip
6	208345	Potentiometer Assy.
7	208323	Gasket, Base
8	302375	LCD - Satellite Bd. Assy.
9	302372	Main Bd. Assy.
10	302276	Chassis
11	208348	Cover & Handle Assy.
12	SMVIN6C500	Screw (2 Req'd)
13	H30006	Headset (Optional)
14	302145	Case
15	B11014	9V Lithium Battery (2 Req'd)
16	208349	Interface Cable Assy.
17	208347	Speaker Cable Assy.

GA-72Cd Repair Parts

SERVICE INFORMATION

If your locator needs service, please return it to the factory along with the following information: Name, Address, Telephone, Fax number, Where Purchased, Date, and Description of Trouble(s). An estimate will be provided prior to service work being done. See shipping information on page 19.

SPECIFICATIONS

(Specifications subject to change without notice)

- Input Power:** Supplied by two lithium 9-V batteries
- Battery Life:** 60 Hours (intermittent usage)
- Output:**
- Audio**
- Output Option Signal increases or decreases in volume
Switch at "A" with gradient-field intensity
- Output Option Signal increases or decreases in frequency
Switch at "B" with gradient-field intensity
- Visual.** Digital readout expanding bar graphs
Indicate polarity (positive or negative) and
Relative strength of the magnetic field
- Battery Check:** BATT 4-segment LCD
- Weight:** Approximately 2.5 lbs. (1.14 kg)
- Operating Temperature:** -13° to 140°F (-25° to 60°C)
- Overall Length:** 34.5 in. (87.6cm)
- Waterproof Length:** 21 in. (53.3cm)
- Nominal Sensor Spacing:** 14 in. (35.6cm)
- Construction:** Rugged, all solid state

LIMITED WARRANTY

The Schonstedt Instrument Company (Schonstedt) warrants each product of its manufacture to be free from defects in material and workmanship subject to the following terms and conditions. The warranty is effective for 5 years (with the return of the Customer Registration Card) after the shipment by Schonstedt to the original purchaser.

Schonstedt's obligation under the warranty is limited to servicing or adjusting any product returned to the factory for this purpose and to replacing any defective part thereof. Such product must be returned by the original purchaser, transportation charges prepaid, with proof in writing, to our satisfaction, of the defect. If the fault has been caused by misuse or abnormal conditions of operation, repairs will be billed at cost. Prior to repair, in this instance, a cost estimate will be submitted. Service or shipping information will be furnished upon notification of the difficulty encountered. Model and serial numbers must be supplied by user. Batteries are specifically excluded under the warranty.

Schonstedt shall not be liable for any injury to persons or property or for any other special or consequential damages sustained or expenses incurred by reason of the use of any Schonstedt product.

FOR SERVICE OR REPAIR

Please ship locator (in its case) to:

Schonstedt Instrument Company
100 Edmond Road
Kearneysville, WV 25430
Attn: Customer Service Dept.

PATENTS

Manufactured under one or more of the following Patents: United States: 4,163,877; 4,258,320; 4,803,773; 4,839,624; 5,097,211; 5,136,245; 5,138,761; 5,239,290. Other United States and foreign patents pending.